



Newsletter

A bi-monthly publication of the American Accordionists' Association

JULY 2012

Here's What's Happening at AAA in 2012

JULY 11-15

AAA Annual Festival
Sheraton City Center
Baltimore, Maryland
Workshops • Exhibits
Concerts • Competition

Guest Artist:

Stas Venglevski

Coordinators: Frank Busso,
Mary Tokarski
and Linda Reed

JULY 27-29

Master Class and Concert
Series – The Seminars
Redemption: The Radar –
Off the Radar

See page 2

Tenri Cultural Institute
43A W13th Street, NYC

Moderator/Curator:

Dr. William Schimmel

SEPTEMBER 8

Noon to 5:00 pm

Valtaro Celebration

Wine tasting, dinner

and dancing

Magnanini Farm Winery

172 Strawridge Rd.

Walkill, NY

See pages 8&9

Chairman: Mario Tacca

Join us as we pay tribute to
the Magnanini Family for
their continued support of
live accordion music!



From the Editor

Welcome to the July 2012 edition of the AAA Newsletter. My sincere thanks to you all for your continued support and submissions of information highlighting the wonderful accordion activities across the USA. My special thanks to Rita Davidson, Editor of the online USA National Accordion News, for her wonderful collaboration and sharing of information for the AAA publications.

In this Newsletter we have launched a new section called "Coast to Coast" profiling some of the diverse accordion activities being held across the country.

I wish you a wonderful summer highlighted by the 74th AAA Competition and Festival in Baltimore, and I look forward to hearing from you all very soon with your accordion news.

Sincerely, Kevin

Kevin Friedrich – AAA Newsletter Editor



Spotlight on AAA Governing Board Member, Manny Bobenrieth

Compiled by Joan Grauman, AAA Historian

On the AAA Governing Board since 2001, Manny Bobenrieth has been an adjudicator and Master of Ceremonies for the AAA festivals and has worked on numerous committees. He brings his warmth and delightful humor into every meeting and event and, this year, he will once again bring his superb skills on the accordion to our annual festival. Manny Bobenrieth and the U.S. Army Strolling Strings will be performing at the AAA Festival banquet in Baltimore, Maryland on Saturday, July 14.

Born in Concepcion, Chile, Manny is one of eight children,

most of whom studied music in their youth. Manny began taking accordion lessons at age 5. When the family moved to the United States and settled in the Washington, D.C. area in 1968, Manny and all of his siblings began studying at Carmelo Pino's Biviano School of Music in Silver Spring, MD. His siblings studied guitar, accordion and trumpet. Nine-year old Manny stayed with the accordion and studied with Carmelo Pino, who became his lifelong mentor and friend.

In 1970, with Carmelo's encouragement, Manny began entering accordion competitions, first in the Accordion



Association of Greater Washington (AAGW) and then in the AAA. He enjoyed the hard work and discipline and did

continued on page 2

Joe Soprani Entertains for Artist Martin Varnedoe

Philadelphia presented an Art Exhibit of Philadelphia's own Martin Varnedoe. Varnedoe's recent collection attempts to capture moments of vibrancy, intimacy and mystery of Italy, everyday situations of ordinary activity in extraordinary settings as seen through the eyes of the artist.

Varnedoe's works may be found in both private collections and in public spaces throughout the United States and abroad. Varnedoe has a Master of Fine Arts from Pratt Institute of New York and among his most notable por-

traits are his paintings of renowned pianist Lili Kraus that were show at the Lincoln

Center and now hang in the Kraus family permanent col-

continued on page 2



Joe (center) is pictured here with Martin Varnedoe and Joseph Robert Colletti. For further information, please visit www.joesoprani.com

Manny Bobenrieth, continued from page 1

well in the competitions. Manny has very fond memories of being judged by such greats as Charles Magnante, Madalena Belfiore, Dr. Jacob Neupauer and Joe Biviano. One memory that stands out for him was the 1976 Coupe Mondiale, a huge gala event that took place at the historic Shoreham Hotel in Washington, D.C. Manny played in Carmelo's student ensemble, competed in the duet category and truly enjoyed being a part of the accordion world.

In 1982, Manny graduated with a Bachelor's degree in Music Performance from Catholic University of America in Washington, D.C., becoming the first accordionist to graduate with such a degree from that institution. He performed in restaurants, on SS Norway's Caribbean cruise lines, with the legendary jazz guitarist, Charlie Byrd, in Broadway musicals and with the Kennedy Center Opera House Orchestra.

In 1986, Manny became the accordionist for the U.S. Army Band "Pershing's Own" Strolling Strings. With the Strings, he has performed for

five presidents at numerous White House State Dinners, in honor of foreign dignitaries such as Margaret Thatcher, Mikhail Gorbachev, Prince Charles and Princess Diana, Boris Yeltsin, King Hussein and many others. In 2001, Master Sergeant Manny Bobenrieth was promoted to Sergeant Major. In 2004, Sergeant Major Bobenrieth became a non-commissioned officer in charge of the U.S. Army Strings. He is responsible for, and oversees all of the commitments for this 22 member group. Manny has also written many of the arrangements that are performed by the Strolling Strings.

Manny and his wife, Maureen, live in Potomac, MD and are very proud parents of two grown children, Emily and Vincent. Emily is a 2011 West Point graduate and is now 2nd Lieutenant with the 82nd Airborne at Fort Bragg, NC. Vincent is going into his senior year at the University of Pittsburgh, majoring in English. Vincent enrolled in ROTC and will be a Commissioned Officer in the U.S. Army next year. ■

Joe Soprani, continued from page 1

lection. The artwork of Robert Colletti, also a Philadelphian, were also on display.

Joe provided entertainment throughout the evening and accompanied tenor Tony Affigato in a variety of Italian selections including "Parlami d'Amore Mariu" and "On An Evening in Roma" as well as classic Neapolitan songs and other Italian favorites.

In addition to performing in Broadway shows such as "Fiddler on the Roof", "Zorba", "Cabaret" and "Irma la Douce", Joe has performed in world premieres of "Frida," a musical that called for a virtuoso accordionist and "Another Kind of Hero," a musical which featured him on stage for an entire scene.

Joe, who appeared on the Ed Sullivan Show and won the Arthur Godfrey Show, appeared with TV Star Nell Carter in a "Colors of Freedom" production at the Con-

vention Center in Philadelphia in 1995. He also appeared with Peter Nero and the Philly Pops playing a special arrangement with Nero with Soprano Evelyn de LaRosa. In November of 1997, Soprani became the first accordionist to perform in "La Traviata" by Verdi presented by the Opera Company of Philadelphia, at the Academy of Music in Philadelphia. Klaus Arp, the opera conductor from Germany, decided to use the accordion in the small ensemble on stage during "La Banda" sections.

Joe has also performed with Russell Watson on Good Morning America, and continues to promote the accordion as a serious instrument at various clubs and organizations. His workshops at schools and colleges, where he demonstrates his skills as performer and arranger to young composers and arrangers, have been well received. ■

18th Annual AAA Master Class and Concert Series

Remember to mark July 27-29 on your calendar. Those are the three days for the 2012 Accordion Master Class and Concert Series "The Seminars" sponsored by the American Accordionists' Association (AAA). It will be moderated by Dr. William Schimmel at the Tenri Cultural Institute of New York located at 43A West 13th, Street in New York City.

This year's event is Redemption: The Radar off the Radar. Curator and Moderator of the event Dr. William Schimmel tells us "it's a new kind of Radar!! Yes, and trust me, it's a new way of Redemption! It's the Radar off the Radar! The Seminars are 18 years old this year and they have found their own place in the marketplace of ideas in a new zone – off the Radar!! Yes, I say again – The Radar off the Radar!! It's a new kind of Radar – and it's looking for you!! It really is!! Yes!!"

The weekend events will include Master Classes at 3 p.m. and Concerts in evening at 7 p.m. featuring a distinguished lineup! Installations in the lobby include Books, CDs, DVDs and other merchandise. ■



**REDEMPTION:
- THE RADAR
- OFF THE RADAR**

JULY 27, 28 and 29, 2012
Tenri Cultural Institute
43A West 13th Street (Between 5th and 6th Avenues)
New York, NY

IT'S A NEW KIND OF RADAR!

wps

A sampling of Concert and Master Class presentations include:**Concert No. 1 on July 27, 2012 at 7 p.m. includes:**

- "New interactive video" by Micki Goodman with Ms. Goodman, video, dance and choreography, music, Dr. Schimmel
- "Star Twinkle - Mix" by Mozart, Cage, Telstar, Doo Wop and "Sonata for two pianos (accordion and piano)" by Mozart performed by Dr. Hugo Goldenzweig, piano and Dr. Schimmel
- "St. John Coltrane!" by Dr. Mark Birnbaum/William Schimmel, performed by Dr. Birnbaum, piano – Dr. Schimmel
- "Kensington" by Dr. Art Bailey "Romp III" by Robert Young McMahan performed by Dr. McMahan - Johanna Cho, piano
- "The Minimal Accordion" by Michael Century
- Plus more!

Master Class No. 2 on July 28, 2012 at 3 PM includes:

- Accordions Occupying Wall Street
- Song Writing at the Accordion
- Don't Just Get Them, But Keep Them (Julio Giulietti)
- How I Achieved Salvation Through The Accordion Without Playing It
- A Bellows Pleated World/Full of Ins and Outs
- Merton/Bhudda/Pussycat (William Schimmel)
- The Reality Chord/Money/Exhibit
- Fire And Worship
- Installation In Lobby – Please Don't Go Away (William Schimmel)
- Music: Gregorsphere (William Schimmel)

Tribute to Sam Fire, by Marilyn O'Neil

It's May 6th, 2012, and the accordion world is celebrating the 183rd anniversary of the day the accordion was patented. I am in a tiny corner of the world, Philadelphia, PA., celebrating World Accordion Day and memorializing the life of my cousin, accordionist Sam Fire, along with his wife, Ruth, his niece, Teresa, Teresa's husband, and several very special friends. Born on December 14, 1931, Sam had passed away a mere 8 weeks ago on March 5, 2012.



Sam Fire in Korea

Nine years prior, at this very time of year in 2003, I'd bought a new accordion and reconnected with my cousin on the phone. I, like many of us, had been away from my beloved instrument since I was 16. Now, at age "50 something," and remembering that Sam was a professional and a family member, I called him.

Thus began a series of conversations during which Cousin Sam gently ushered me back to my first musical love; encouraging, educating and sharing his life history with me.

Sam started playing the accordion at age 9, studying the original Pietro Deiro method with Silvio Micucci for about 5 years. He recalled that the Junior Band was rehearsing on the day Pearl Harbor was attacked in 1941. When he was about 13, Sam met Deiro at Silvio's school and shook the Maestro's hand.

He noted that his teacher placed him on a trailer at a war bonds rally playing a 48 bass accordion. By the age of 15, he was playing a 120 bass instrument with his name on it. Silvio got Sam his first paying job in a bar on Frankfort Avenue in Philadelphia. This would be the first of many gigs with a mix of various musicians.

Sam played accordion in his high school band, but had to stop because his father wouldn't allow him to play his new accordion in the rain. He was studying Academic Music in high school. This involved 7 hours of music training in addition to regular academics. There he met John Felice, a man Sam would eventually teach for at Felice's Music School. Sam heralded Felice as the "best player of all time." Sam graduated high school in 1949, one year before the Korean War began.

After high school, Sam continued accordion lessons with Andy Arcari, an entertainer in Philadelphia. He described Mr. Arcari as a "Dick Contino type." He'd also begun work as a surveyor, first privately and then for the City of Philadelphia.

At the age of 20, Cousin Sam was drafted into the Army. He went on to Korea, which he consistently described as a "hell-hole." He spent 16 months

continued on page 4



Sam Fire

The accordion "is more than a polka instrument. It's anything you want it to be."

Long Island Accordion Alliance (LIAA) Summer Concerts

The June 5th edition of the Long Island Accordion Alliance featured the internationally acclaimed concert accordionist and AAA Board of Director Mary Tokarski.



Pictured are from left to right: Mary Tokarski, Dominic Karcic and Don Gerundo

Mary performed a wonderful program of concert solos which included "Ave Maria" by J. S. Bach / Charles Gounod, "March of the Toys" by Victor Herbert, "Malaguena" by Ernesto Lecuona and "Tea for Two" by Vincent Youmans. The packed house of accordionists and accordion music lovers treated Mary to a rousing standing ovation at the conclusion of her performance. The videos and pictures from the event are posted at: trietsch.smugmug.com

The July 3rd event featured Don Gerundo and guitarist Dave Hirschman. Don is an active accordionist and pianist performing in the New York metropolitan area. He is a versatile keyboardist who plays various styles ranging from popular standards from the American Songbook, jazz and rock 'n roll. He works with the Bensen-Scott Big Band, an 18 piece jazz band and has also worked with a rockabilly small group as well as society combos and "top 40 groups." He has performed and accompanied Lenny Welch (hit record "Since I Fell For You"), Joe Piscopo and has performed at Swing 46 in New York City, White Plains Theatre for the Arts, Coney Island Park and other large venues.

Don starting playing the accordion at age 10. During his later teens he studied with Tony Mecca (a native from Waterbury, CT.) Tony introduced him to popular and jazz music and worked with him on harmony, theory and improvisation. During this time he started to perform club dates with some of the local leaders in the New York metropolitan area as well as work at resorts in the New York Catskill area. This "on the job" training helped hone his jazz skills, as well as build his repertoire.

For the last several years Don has focused on the "free bass accordion" and exploring its use in the pop and jazz Idioms by utilizing its flexibility in chord voicings, bass lines and general accompaniment.

Don is also an experienced user of Finale (music notation software) and has used it almost from its inception (1992). He uses it to create arrangements, generate materials for students, create transcriptions, as well as composition. Don will be presenting a workshop on the use of Finale at the upcoming AAA Festival in Baltimore.

The LIAA holds their events at La Villini Restaurant, located at 288 Larkfield Road in East Northport, NY, phone: (631) 261-6344. ■

**AAA 75TH ANNIVERSARY
AUGUST 14-18, 2013
The New Yorker Hotel**

A Tribute to Sam Fire, cont'd.

of a 2 year Army stint in Korea. There, he worked in a prison camp, guarding prisoners and preparing them to be exchanged for U.S. Prisoners of War. Eventually, he was promoted to Division Artillery. The last 6 weeks of his tour of duty, he got hold of an accordion. Joined by a bass and clarinet player, the young soldiers played in the officers' club that he described as a "MASH-like" atmosphere. They were treated "like gold." No more guard duty! Sam spoke of those last 6 weeks as a "nice ending to a really bad experience." He often said he was saved by the accordion at that time.

One of the highest points of his Army career came when he happened upon another accordionist, Mr. Joseph Soprani, who was playing with a USO show. Sam introduced himself to Soprani, and the 2 boys realized they were both from Philadelphia!! Sam, full of excitement and awe, wrote to his parents about the meeting.

Soprani had made it through his own trials while on tour, having survived a plane crash carrying a group of musicians over Japanese waters, nearly losing his life. Soprani's accordion, as well as all of the other instruments on that plane, were lost in the sea. Luckily, the musicians made it to shore, Soprani holding on to a lifeboat that towed him 4 miles in freezing waters to safety. Joe went on to enlist in the Air Force and, with the Air Force Band, enjoyed a stellar 4 year long career as a musician playing the accordion. He also continued accomplishing, competing in world events and playing for famous singers and musicians, among them Luciano Pavarotti and Bon Jovi.

After Korea, Sam returned home and continued his musical studies with Lenny Payton, learning chord structure, arranging, harmonies, etc. He married the love of his life, Ruth Drasdis, a woman he described as someone who calmed him, just like

the accordion did. Sam enjoyed many years playing with various bands, some formal combos that lasted for years, others just one night stands that he played while serving as a union musician. Among the formal bands were the "Viscounts," "Four Men from Swing," and the "Regals." We spent hours laughing together at the mishaps and unexpected occurrences that he encountered during his various gigs. He was also self taught as an accordion repairman.

Sam was a proud member of the American Accordionists' Association since the 1970's, and was honored by The American Accordion Musical Society in 1997 for his contribution to the accordion. He said many times that he played to please people, portraying emotion in his music that would make a room go silent. He preferred "pure accordion" over synthesized music, and always stressed that the accordion "*is more than a polka instrument. It's anything you want it to be.*"

He encouraged me to "get the accordion out there" as I, along with Mary Tokarski, started the Connecticut Accordion Association (CAA) in 2004. He wrote an arrangement of "In The Mood" that the CAA orchestra played at its debut concert in 2005.

Back to May, 2012. Among the group gathered in Sam's livingroom are two beloved friends. One is Joseph Soprani, who Sam reunited with in 2003. The other is a former devoted student of Sam's, Kurt Marin. The two men picked up two of Sam's most prized instruments and, in the presence of people who loved him, played an impromptu concert in his memory, a compilation of classical, jazz favorites, and familiar Italian tunes. I realized that while the whole world celebrated World Accordion Day, I celebrated the life of a man, my cousin, whose world was the accordion. ■

Rest In Peace, dear Cousin.

Love, Marilyn

AWAM Museum Corner - An Early American Free-Bass Piano Accordion

by Helmi Strahl Harrington, Ph.D.

A World of Accordions Museum had a very happy Thanksgiving celebration when we brought home 74 accordions and concertinas, 40+ harmonicas, and a bass myrba (sansa). A well-known instrument museum had invited us to accept their de-acquisitioned free reed instruments that included rare, beautiful, and valuable examples of all types of accordion-family instruments obtained over decades from around the world. To accommodate our new pieces, ten additional displays were erected, our previous 140 racks became crowded with more dazzling examples, and our number of exhibited instruments rose to over 1,300.

Particularly fortunate inclusions among the piano accordions are two nearly identical, entirely complete instruments apparently constructed in close sequence, allowing a rare opportunity for comparison. The one presumed older is finished with a dark brown wood façade, retains a trumpet horn, one shoulder and bass strap, black cheesecloth lining fabrics, and is generally less well preserved with evidence of water damage. Its partner is finished with black wood veneer and has undergone modernizing effects. These include re-taped and patterned bellows, silver lame grill cloths, bellows frame screws and strap closures (instead of latches), pressed aluminum decorations which cover trumpet-horn holes, and newer shoulder and bass straps. It weighs 16 lbs. 2 lbs. less than its brown partner, presumably resulting from use of newer aluminum reed plates.

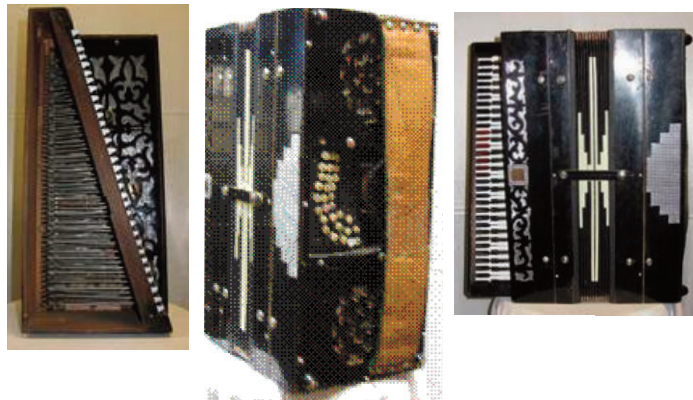

Both instruments share certain features: unusually narrow width of the 54 treble keys set diagonally for easy view by the player, close spacing of 31 single-pitch bass buttons positioned as insets to the bass-plate and arced to fit fingers of the hand without more than wrist angle movements, a spring-held air lever near the left hand thumb, simple polished wood veneer, Viennese style scroll-cut décor, a box-like structure of 16"x7.5" size and wood bumpers that serve as feet.

Both instruments are outfitted with octave couplers affecting the irregular five treble and four bass reed banks. The treble sections have two coupled sliders on the grill that engage the LMMM(M) reed banks; the bass sections have one pincer-action shift at the palm that controls the C1 C2 C2 C3 reed banks. Double-tongue reed plates are attached by turnstiles over leather sealant strips; zinc and steel palates and rods have an unrefined presentation suggesting small-workshop assembly.

In researching the origin of these instruments, no maker's name, logo, internal script or stamp identifies company or country of origin. No reference books found in the museum library came close to identifying the salient features. But there are clues yet to be tracked, such

continued on next page

AWAM Museum Corner, continued

as, where the colorful abstract design of the bellows lining paper was made. Clearly some German connections exist: penciled on the reed block spines of both instruments are pitch names written in old-German script by the same hand. The word "Oben" (above) is found on the older example along with entirely German spellings of pitches. On the spines of the younger, names are mixed between German and English. Perhaps the writer was becoming Americanized.

In our patents library we found U.S. patent No. 268,819, taken by Karl Stieglmayer of New York on April 10, 1928, to describe an instrument named "Jazz Organ" as follows: The main object of this invention is to provide a musical instrument of the accordion type... having an inclined keyboard on which a full set of keys may be mounted. The keys, due to the shortness of the key-board, are quite close together and are specially constructed ... so that they may be easily manipulated by the fingers.

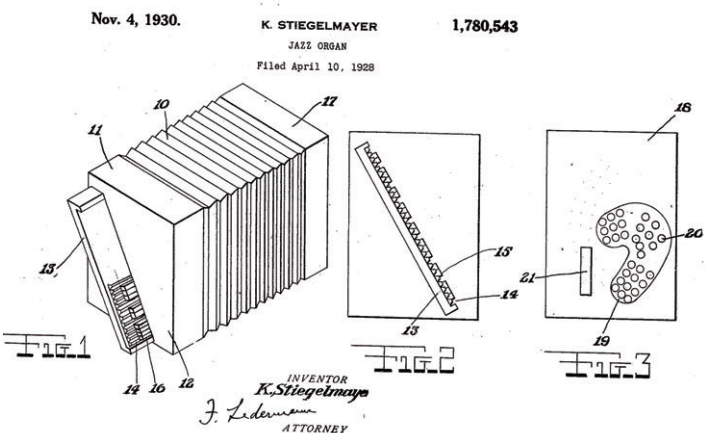

With this accordion design I think we see yet another convergence of elements from different accordion-family instrument types that run throughout the history of our organology. The Encyclopedia of New York City mentions that by the 1920s thousands of immigrant German families had settled in the area, including musical instrument makers and performers. From German sources we are told that both the Franz and Arnold families emigrated from Germany and settled on the East Coast; both were known to produce experimental instruments of concertina/bandoneon square-box types with single-tone bass sections. It was also the time and place that spurred Piazzolla's bandoneon style. With the area's strong influence on jazz, and from the patent name, we may presume these accordions were intended to participate with a free-bass order familiar to players.

Outer row on a raised platform: Bb G# F# E C Bb F# A C Bb
Middle row: C# A Bb D B D F G# B D
Palm row: Bb F G _ Bb C# E G A#

Some of the pitches of our piano accordions' bass sections are yet difficult to determine and will require careful reed restorations before accuracy of the sequence can be asserted. At this point, the logic of bass pitch arrangement remains unclear, but comparison to charts developed by Maria Dunkel on the evolution of bandoneons and concertinas appears promising.

Readers with additional insights are encouraged to contact us. ■

Music Under New York (MUNY) features Accordionists

At present, more than 350 individual performers and music ensembles participate in over 7,500 annual performances in approximately 25 locations throughout the New York City transit system. Through Music Under New York (MUNY), a variety of performances are available to the public within the transit network in a variety of genres, with instruments ranging from Gambian kora and Korean drum to our beloved accordion.



Pictured above, Matt Dallow at Grand Central Station. At right, Julie Chang, Fox News Anchor

Some 75 soloists and groups auditioned to join the roster for MUNY at the recent open audi-



tions held at Grand Central Station. Among the hopefuls were accordionists Marin Ciotoi, Matt Dallow (pictured) and Mellisa Elledge. Fox News Channel 5 News Anchor Julie Chang who delighted in taking Mellisa's instrument during coverage of the event to try her hand at the accordion.

Starting in 1985, MUNY is one of the many visual and performing arts programs administered by the Metropolitan Transportation Authority's Arts for Transit office that increases the attractiveness of transit facilities for customers. Performers accepted into the program are scheduled at locations in subway and commuter rail stations including the Long Island Railroad (LIRR), and Metro North. Sites have been selected with the approval of the station managers, police and NY City Transit Stations and system safety departments. Currently on the 2012 MUNY roster are accordionists Yuri Zak and Mitu Busuioac. ■

New York Also Features Accordion 'Above Ground' At Bryant Park

In 1686, the area now known as Bryant Park in the heart of New York City, was designated public property by New York Colonial Governor Thomas Dongan. After being routed by the British in the Battle of Long Island, at the start of the Revolutionary War, General Washington's troops raced across the site. In *continued on next page*



Join for free at:
www.iGive.com/AmerAccord

Accordion at Bryant Park, cont'd.

1807, the grid system of streets was laid out in what is now considered midtown, expanding north from the already cosmopolitan downtown Manhattan. Fifteen years later, in 1822, the land came under the jurisdiction of New York City, and one year later, was turned into a potter's field. The city decommissioned the potter's field in 1840, in preparation for construction of the Croton Reservoir on the adjacent plot of land (now the Central branch of the New York Public Library).

Jump forward some 150 years, and in 1992, Bryant Park Corporation (BPC) completed one of the world's most dramatic urban public space transformations. Now in 2012, celebrating the 20th anniversary of being New York City's town square, Bryant Park attracts more than 6 million annual visitors featuring hundreds of free events, programs, activities, and year-round amenities.

Some of those 6 million visitors enjoy the sounds of accordion music during its summer Bryant Park Accordion concert series when New York accordionists are featured from 12:30 - 2:30 p.m. in the main Plaza at the peak lunch hour. Upcoming performances include: July 2, 3, 6, 2012: Tony Kovatch, August 6, 7, 10: Suzanne Davenport and August 13, 14, 17: Bob Goldberg. Other performers on the Bryant Park Accordion Lunchtime Concert Series are Benjamin Ickies, Rachelle Garniez, Matthew Fass and Harlan Muir.

Bryant Park is situated behind the New York Public Library in midtown Manhattan, between 40th and 42nd Streets & Fifth and Sixth Avenues. For more information, please visit: <http://bryant-park.org/plan-your-visit/accordion.html> ■

Studio Jams to Visit AAA Festival in Baltimore

Studio Jams is a creative, up-close and inside look at the art of making music. It's a program that is dedicated to presenting interesting and innovative music education. Each 1-hour episode features a diverse group of talented musicians.

Their upcoming featured festival will be the AAA Competition and Festival in Baltimore, MD (USA) where they will film and interview participants of the four day gathering profiling the many workshops, exhibits, seminars, competitions and concerts given by accordionists of all ages.

The AAA will view and approve the program prior to release and is very excited to have this opportunity to work with Studio Jams for their upcoming presentation.

For more information on their work, please visit: <http://studio-jams.com> ■



Cory Pesaturo Joins Boston Red Sox for New CD

2012 is the 100th anniversary of the Boston Red Sox's famous Fenway Park. The baseball team has put together a festive and fun album of songs recorded by current and former players, along with the help of some notable guest musicians including Cory Pesaturo, accordionist.

Officially sanctioned and licensed by MLB, the recording is a collection of songs familiar to Red Sox fans, the type of music commonly heard at games, as well as some songs from iconic Boston-area acts.

Red Sox players who participated in the project include David "Big Papi" Ortiz, who provides background vocals and improvises on "Sweet Caroline." Ryan Kalish and Darnell McDonald can also be heard on background vocals. Additionally, Clay Buchholz plays acoustic guitar on the track. Jarrod Saltalamacchia lends some additional guitar licks to "Dream On" and Alfredo Aceves handles co-lead guitar on "Dirty Water." Also on the CD are Jacoby Ellsbury, Dustin Pedroia and Kevin Youkilis who provides percussion on the track, "2007 a musical celebration of the team's most recent World Championship. Daniel Bard plays acoustic guitar on the album's debut single, "Let the Good Times Roll,"

Former pitcher and fan favorites Curt Schilling and Kevin Millar, both key members of the team's 2004 World Series run, are on the CD. Musical guests include one-time Van Halen vocalist Gary Cherone, Extreme guitarist Nuno Bettencourt, Ken Casey of the Dropkick Murphys, International Accordion Champion Cory Pesaturo, J. Geils Band keyboardist Seth Justman, Mike Mushok of Staind, Dicky Barrett of Mighty Mighty Bosstones, and MLB journalist Peter Gammons.

Cory won the CIA International Competition for Digital Accordion in Auckland, New Zealand in 2009 while representing the AAA and more recently the International Primus Ikaalinen VII, a live televised international competition held in Finland. For further information: CoryPesaturo@corypesaturo.com ■

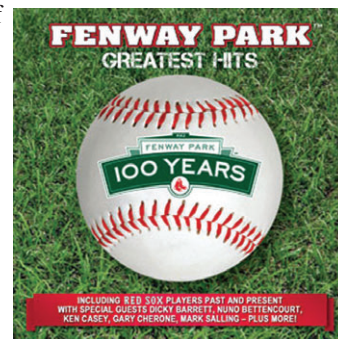

USA Provides Most Viewers For Live World Accordion Day Broadcast

The Confédération Internationale des Accordéonistes (CIA) World Accordion Day Live Video featuring 24 hours of accordion music from around the world was a huge success with viewers from around the world watching contributions from many different nations, performers, teachers and associations. The show was directed and produced by Grayson Masefield, Frédéric Deschamps and Mike Rossi, and is available for viewing in 24 separate hours of archived video coverage.

Coordinator and Co-Presenter Grayson Masefield and co-host Frédéric Deschamps offer their sincerest thanks to all the participants of this year's World Accordion Day 2012, including the

AAA. "Whether you were interviewed, a performer, sent in a video, commented on the live chat or even just watched, this event couldn't have been possible without you. Thank you to the Confédération Internationale des Accordéonistes (CIA) for creating World Accordion Day in 2009 and their continuous support and promotion of the accordion around the world. Also we must mention the members of the CIA Executive Board that took part with in this event: Raymond Bodell, Kevin Friedrich, Kimmo Mattila, Joan Sommers, Herbert Scheibenreif, Harley Jones and Mirco Patarini plus members of the CIA Music Committee: Viatcheslav Semi-

continued on page 7

World Accordion Day, cont'd. from page 6

onov, Andreas Nebl and Li Cong. There must of course be a very sincere thank you to our technical director Mike Rossi. His efforts and improvisation are greatly appreciated, especially as we were receiving videos throughout the live 24 hours and thanks to Harley Jones (creator of www.accordions.com) for his promotion and support of the event.



The mammoth undertaking, the first of its kind in the accordion world, was a worldwide success with over 310,365 minutes viewed and over 20,160 connections from over 87 countries. Congratulations must be given to the countries with the highest viewers: 1. USA, 2. France 3. UK 4. Chile 5. Russia 6. Germany 7. Canada 8. Italy 9. Greece and 10. Finland. It proves that the accordion world is a real family no matter what level, whether beginner or professional or what genre they choose to play (Classical, Traditional, Jazz, Arabic, Contemporary, Ensemble etc.)

The videos are available for viewing at www.accordions.com/cia/cia_wad_directory_2012.htm ■

Dr. Robert Young McMahan in 'Il Postino' (The Postman)

In May, Dr. Robert Young McMahan performed on stage and in costume with the Philadelphia-based Center City Opera, in the East Coast premiere of *Il Postino* ("The Postman"), by Daniel Catán (1949-2011). The production took place at the Prince Music Theater, near City Hall.

The opera is based upon a popular 1994 Italian film directed by Michael Radford. It is a fictional story in which the real life Chilean poet Pablo Neruda (temporarily exiled from his country) forms a relationship with a simple Italian postman who learns to love poetry. The screenplay was adapted by Anna Pavignano, Michael Radford,



Furio Scarpelli, Giacomo Scarpelli, and Massimo Troisi from the novel "Ardiente paciencia" by Antonio Skármeta. Skármeta himself had previously adapted his novel for the screen in 1985 as "Ardiente paciencia" ("Burning Patience").

continued on page 8

Pauline Oliveros Receives \$50,000 Award!

"Through Pauline Oliveros and Deep Listening, I finally know what harmony is... It's about the pleasure of making music." - John Cage, 1989

As she celebrates her 80th birthday year, accordionist and composer Pauline Oliveros has been named the winner of the 2012 John Cage Award, given biennially by the Foundation for Contemporary Arts (FCA). This prestigious \$50,000 award was established in 1992 in honor of the late composer, who was one of FCA's founders. Selected by FCA's Directors, the John Cage Award is made in recognition of outstanding achievement in the arts for work that reflects the spirit of John Cage. Pauline received the award in a ceremony in New York City. "FCA is pleased to honor Ms. Oliveros' many accomplishments in music/sound with the 2012 John Cage Award," says Stacy Stark, executive director of FCA. "She joins a distinguished and small group of artists who have been recognized for their groundbreaking work in the performing arts and who reflect the spirit of John Cage." Founded and guided by artists, FCA's mission is to encourage, sponsor and promote innovative work in the arts and the nonrestrictive award is available for use at the recipients discretion.

"I am honored and delighted to receive the John Cage Award," says Pauline Oliveros. "May the freedom that Cage inspired with his work continue to spread, sustain and open minds throughout the world."

Oliveros is a senior figure in contemporary American music and founder of the Deep Listening Institute of Kingston, NY. Since the 1960s, Oliveros has worked with improvisation,

meditation, electronic music, myth and ritual. In addition to the John Cage Award, Oliveros was honored with the William Schuman Award in 2010. She was honored in 1985 with a retrospective at the Kennedy Center for the Performing Arts in Washington, D.C., and represented the United States at the 1970 World's Fair in Osaka, Japan.

Oliveros has built a loyal following through her accordion concerts, recordings and publications, and musical compositions that she has written for soloists and ensembles in music, dance, theater and inter-arts companies. She has also provided leadership within the music community from her early years as the first director of the Center for Contemporary Music (formerly the Tape Music Center at Mills), director of the Center for Music Experiment during her 14-year tenure as professor of music at the University of California at San Diego, and acting in an advisory capacity for organizations such as The National Endowment for the Arts, The New York State Council for the Arts and many private foundations.

Through her work at universities and colleges, including Oberlin College Conservatory of Music and Bard College, she has influenced generations of young composers. Additionally, Oliveros is a Distinguished Research Professor of Music at Rensselaer Polytechnic Institute and a Darius Milhaud Composer-in-Residence at Mills College in Oakland, CA.

Please visit <http://www.paulineoliveros.us> for the variety of activities held throughout 2012 in celebration of her 80th Birthday. ■



Joan C. Sommers to Direct World Accordion Orchestra VI in Italy

Following the very successful inaugural World Accordion Orchestra debut performance at the USA AAA/ATG hosted Coupe Mondiale 2007 under the Musical Direction of Joan C. Sommers, the magnificent staging of the CIA World Accordion Orchestra (WAO) II in Scotland in 2008, WAO III in Auckland, New Zealand, WAO IV in Varaždin, Croatia, WAO V in Shanghai, China, the CIA is delighted to announce that World Accordion Orchestra VI will be held during the 65th Coupe Mondiale in Spoleto, Italy at the Gala CIA Concert on August 24, 2012.

The World Accordion Orchestra VI, made up from members of the CIA Executive and Music Committees, CIA member nation delegates and fellow orchestra members of groups from Germany to Brazil, will perform two pieces: Paragon March by Anthony Galla-Rini and "Selections from E.T. the Extra-Terrestrial" by John Williams, arr. by Joan Cochran Sommers.

The "Paragon March" is a 1947 original work by the renowned accordionist, one of the founding members of AAA and former CIA Vice President Anthony Galla-Rini, while the magnificent blockbuster arrangement by current CIA Vice President Joan Cochran Sommers of "Selections from E.T. the Extra-Terrestrial" is a large symphonic one and includes the main themes from the motion picture with various reprises of the "Flying" Theme and the "Bike Race."

Joan C. Sommers has held positions in several music organisations, including the Accordionists & Teachers Guild International (ATG) and the Confédération Internationale des Accordéonistes (CIA – IMC-UNESCO). She continues to adjudicate, coach soloists, prepare accordion orchestra arrangements, and conduct accordion orchestras regularly, and currently proudly serves as a CIA Vice President. ■

McMahan in 'Il Postino', cont'd from page 7

The accordion appears in the last scene of Act 2, depicting the postman's wedding reception, and accompanies Neruda (portrayed by tenor Hugo Vera in this production) in a love song. This is followed by a tango played by both accordion and orchestra in which the entire wedding party participates both in dancing and singing. Though the film was in Italian and the story takes place in a remote island off the southern end of Italy in the mid-1950s, the libretto is in Spanish, reflecting the Princeton University educated Catán's Mexican origins and his desire to reach Latino-American audiences.

The world premiere took place in Los Angeles in 2010, with the famed tenor Plácido Domingo playing Neruda. Nick Ariondo was the accordionist for that production, which may be seen in its entirety on the PBS website, scroll to 1 hour, 31 minutes to see the accordion scene). The Center City Opera production was a smaller-scaled, lower budgeted one than that of the Los Angeles one, again fulfilling the late composer's wish that his operas get out to more of the rank-and-file audiences on a wide scale via smaller companies. Catán's widow was present at one of the Center City evenings to promote this passionate wish of her husband, who sadly died suddenly in 2011.

As a classical artist, Dr. McMahan, a member of the AAA Board of Directors and Chair of the AAA Composer's Commissioning Committee, has dedicated a major part of his career to the promotion of the accordion in serious contemporary music through recitals, concert appearances, teaching, recordings, publication of his music, journal articles, participation in contemporary music organizations, and including it in many of his own compositions. He has been instrumental in convincing other composers, such as Dr. Samuel Adler, Lukas Foss and Robert Hall Lewis, to use it in their music and has, himself, been commissioned to write works for it by various individuals and organizations, including the American Accordionists' Association and the New York State Council on the Arts. He will be contributing to the first-time chapter for the accordion in the new edition of Dr. Adler's celebrated textbook on orchestration. He has recorded on the CRS and Orion labels, was accordionist for the Baltimore Symphony during his years of residence in that region and has recently served in a similar way with the Princeton Symphony and the American Symphony. ■

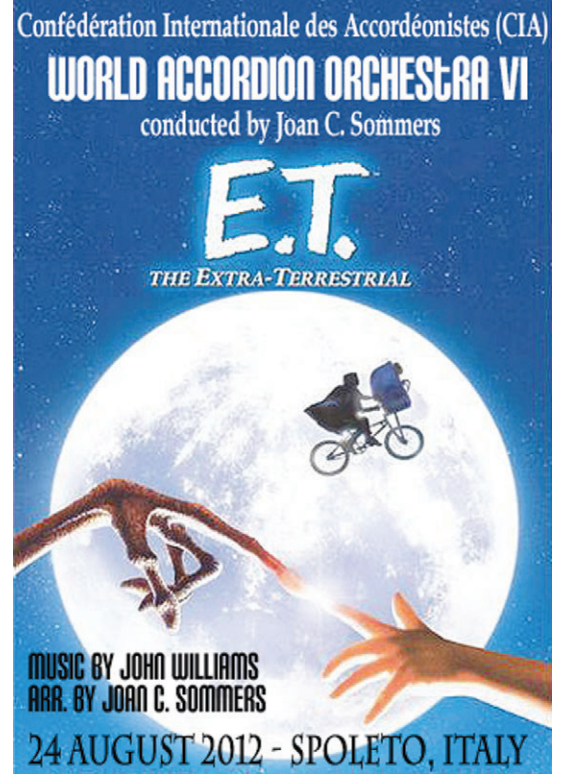

AAA Valtaro Celebration - Sept. 8th Magnanini Farm Winery

The AAA Valtaro Celebration on September 8th, 2012, at the Magnanini Winery in Walkill, NY, will honor the Magnanini Family for their continuous support of live accordion music at their establishment.

Great food, wine, company and great accordion music was the vision of Rick's father, Galba Magnanini, and he made it a successful reality. Today the family tradition is continued with devotion and dedication by Rick and Rachel Magnanini along with their two sons, Robert and David.

The family background is fascinating. The Magnanini family is originally from the Emilia-Romagna region in Northern Italy. The Magnanini farm in Walkill, NY was obtained in 1951. It was originally an old apple orchard and dairy farm, on 35 acres. In

1970, the land was cleared and the vineyard was planted. Richard, Galba's son, who was graduated from SUNY Delhi for



Magnanini Winery Founder,
Galba Magnanini

continued on page 9



Coast to Coast

...a sampling of accordion events across the USA!

New Feature.
See pages 10 and 11

AAA Valtaro Celebration - Sept. 8th, cont'd.

agriculture, works closely with Cornell University on Viticulture and Enology practices. In 1976, Gov. Mario Cuomo passed "The Farm Winery" bill which allowed small grape farmers, who made wine, to sell it on their premises. In 1976, Galba and Richard started making wine from their own vineyards, for home and friends and the rest was sold to Brotherhood Winery. In 1980, they started to build the restaurant from a two car garage. Many people were skeptical but they pursued their dream. In 1983, Richard obtained his license to sell wine thinking what better way to sell their wine than with homemade specialties such as tagliatelle, ravioli, capelletti, and provisions; salami, coppa, sausage and cotechino.

Joseph Trombetti, a retired executive chef from The Plaza Hotel in NYC, a good friend of Gelso and Galba, was the Mag-

year. Over the years, Richard has won numerous awards for his wines, of which he is very proud. Today Richard's work at the winery revolves around bottling, processing their own meats, preparing food for the restaurant, making their own pasta and sauces, all vegetables locally grown and hand picked.

The Restaurant opened on Easter Sunday 1985, with a full house. There was live accordion music played by the "Good Time Band" consisting of Richard Magnanini and Danny Coan on accordion and Jack Ragazzi on bass guitar. The music was from the Valtaro region. It is fascinating to learn that Galba and Gelso Pelligrini were from the same part of Italy. Galba would hear Gelso perform at different functions in the NY area and they became friends. Gelso saw the winery being built and said that he would play there. In 1989, Gelso Pellegrini



Rachel and Rick Magnanini

the accordion by his father, Galba, who played by ear. Rick took lessons from Steven Harer of Clifton who had studied with Pietro Deiro and Frosini.

In 1990, the Valtaro reunions began. Gelso Pelligrini was instrumental in keeping the Valtaro heritage alive. Along with good homemade foods of the Emilia-Romagna region and Valtaro music, everything came together. In 1994 the addition of the dance area and bandstand was completed.

Gelso continued to perform with his colleagues at the winery until his passing in Jan. 2002. Through Gelso, the Magnanini's met Mario Tacca and Mary Mancini. Other accordionists who have performed there include Frank Toscano, Frank Carozza, Manny Carallo, Angelo Di Pippo, Charles Nunzio, Ray Oreggio, and Dominic Karcic. Carmen Carozza, a close friend of Gelso's, also played there. Rick said, "People really like the accordion. I, as do many other people, have very fond memories of the accordion at family functions. People really enjoy the focus on the accordion at the Magnanini Winery."

The Magnanini family continues to keep the tradition of the Italian cuisine and the accordion preserving the family heritage. Mario Tacca, along with Frank Carozza, Dominic Karcic and Frank Toscano presently play at the winery. Rick said, "The Magnanini

Winery is a gathering place of Valtaro musicians and friends of the accordion. Anybody that loves the accordion would come here. Many heard about it through the grapevine. It is a very relaxing way to spend an afternoon. We were fortunate to have all these wonderful people as friends. And this is what makes the Magnanini Winery what it is today....We carry on the tradition of great food, music, friendship, and wine." Rick met his wife, Rachel, when he was playing with his band and she was waitressing for her nursing degree. The beautiful artwork displayed on the walls are all originals painted by Renzo Magnanini, older brother of Galba. Renzo was also a renowned sculptor and artist from Bologna, Italy. Because the family is totally involved in every aspect of the business, the result is an excellent, unique opportunity for all to have a wonderful time. ■

Join us on Saturday, September 8th, to celebrate the traditions of the Magnanini family for an afternoon of good music, good food, good wine and good times! See information regarding this event that is included with this newsletter.



Valtaro accordionists Gelso Pelligrini, Willy Brunelli, Ugo Nati, Peter Spagnoli . Circa 1989 Reunion

nanini's mentor over the years, helping them to acquire excellent kitchen skills and methods of efficiently serving large groups. The restaurant was completed and the wine was ready to sell. The first years production of 1000 gallons was sold out! More vines were planted. The second year 2000 gallons were also sold out. As the vineyard grew so did the sales presently producing 6000 gallons, which equals 25-30 thousand bottles of wine each

began to perform at Magnanini's continuing until 2001. Gelso, one of the original Valtaro accordionists, would perform there as did Pete Spagnoli, John Brugnoli, and Pet DelGrosso. They would all meet at the Magnanini Winery and play together. Rick said, "Right from the beginning the focus was on the accordion. The accordion and the food makes it a lively fun event. The accordion makes everyone happy". Rick was introduced to

Coast to Coast

...a sampling of accordion events across the USA!



LISLE, CHICAGO, IL

The Accordionists and Teachers' Guild, International (ATG), the fellow USA member of the Confédération Internationale des Accordéonistes (CIA) with the American Accordionists' Association (AAA), will hold their summer festival from in Lisle (Chicago), Illinois - July 25-29, 2012.

This year, the 72nd ATG Competition and Festival will feature renowned Russian accordionist Ioisf Puritz, Jazz accordionist Jeff Lisenby, Roland artist Alicia Baker, University teacher Marko Petričić and popular Milwaukee based artist Stas Venglevski. In addition, the festival will showcase the Gene Van Accordion Orchestra, the UMKC Chamber Accordion Ensemble, the Soundscape Trio, Betty Jo Simon, Amy Jo Sawyer, Tony Hermanek, Donna Dee Anderson, Esther Lanting, Gordon Kohl and Marion Jacobson.

The 2012 ATG Festival Orchestra coordinated by Joan C. Sommers will unite all attendees, and will be joined in concert by the renowned Youth Choir from Chicago 'ANIMA'. Just returning from an exciting Concert Tour of Europe, ANIMA will be featured with the Festival Orchestra on the magnificent arrangement of 'Let There Be Peace on Earth'.

The AAA and ATG recently co-sponsored the CIA Coupe Mondiale in Alexandria, VA, organized by Faithe Deffner. This co-hosted event was the most successful International Accordion Festival to have ever been held in the USA. Currently Faithe Deffner, Kevin Friedrich and Mary Tokarski each serve as members of the Board of Directors for both the AAA and the ATG.

For more information,

please visit: www.accordions.com/atg

SOUTH RIVER, NJ

The Accordion Pops Orchestra directed by Al Terzo presented their Spring Concert on Sunday June 10, at the Imperial Music Center in South River, NJ.

Renowned accordion champions Beverly Curnow and Mary Tokarski performed as guest artists. Also featured were Albert Manginelli (accordion) and Nicole D'Angelo (piano), champions from the recent 2012 Mid Atlantic Music Teachers Guild competition.

The largest professional accordion orchestra of its kind on the East Coast, the group consists entirely of accordions plus percussion instruments. In addition, the orchestra often accompanies guest soloists including pianists and vocal artists.

For further information about engaging the orchestra for a concert, future concerts or joining the orchestra, please contact: webmaster@accordionpops.com

EAST NORTHPORT, NY

The Long Island Accordion Alliance (LIAA) and La Villini Restaurant presents an evening of accordion music and featured guest artist vocalist Connie Shakalis accompanied by accordionist Dominic Karcic on Tuesday, August 7, 2012 at 7 p.m.

Connie Shakalis is an award-winning vocalist from Huntington Station, NY. She has sung in many of the top cabarets in New York City as well as performing 20 lead roles in musicals throughout the U.S. She has performed with Van Johnson, Edie Adams, and Robert Morse (who currently appears as the ad agency boss on the popular TV series "Mad Men." She is a soloist with the "Music on

the Sound" opera series in Port Jefferson, NY. Her program on August 7th will feature a wide range of songs from opera, operetta, Broadway musicals and ethnic folk melodies. Please join us for a terrific evening of accordion music and song!

In addition, join us September 4th for our September-Octoberfest! Ein Prosit! La Villini Restaurant is located at 288 Larkfield Road in East Northport, NY, phone: (631) 261-6344

NASHUA, NH

The Fifth Annual ACCORDIONS NOW! Music Festival, co-sponsored by New Hampshire Accordion Association and Accordion Connection LLC, will be held August 17-18, 2012 at the beautiful Courtyard Marriott in Nashua, New Hampshire. It will be a high-spirited weekend filled with warm friendship and great music. Sign up, bring your accordion, and join the fun!

Artists and presenters include: Tony Lovello, Christopher Gorton, Brent Buswell, Jeremiah McLane & Anнемieke Spoelstra, Gary Morin, Donna Maria Regis, the ACCORDIONS NOW! Festival Orchestra, Dan Mackowiak, Sam Falcetti, and others to be announced soon.

Be part of the musical action and bring your accordion! You have many opportunities to participate. For more information: Accordions Now! phone: (603) 216-9582 or email: AccordionsNow@yahoo.com

SILVER FALLS, OR

Rose City Accordion Club hosted their Accordion Club Camp from June 10-15 at the Silver Falls State Park Conference Center in Oregon. President Wayne Tiusanen and the Club hosted five days of intense work-

shops, individual one-on-one instruction, playing music as part of an accordion orchestra, jamming and making new friends.

The Rose City Accordion Club of Portland, Oregon, a non profit organization was formed in 1996 by a group of people of all ages who love playing the accordion. Many of the members go out into the community and volunteer to perform at senior citizen centers, schools, and retirement communities.

The Rose City Accordion Club is open to all accordion players, from beginners to professionals, their friends and families, and to anyone who enjoys music. Meetings are held monthly on the third Saturday of each month at the Milwaukie Public Safety Building, 3200 SE Harrison Street (SE 32nd and Harrison), Milwaukie OR, from 1:00 to 5:00 PM. For further information email: squeezebox21@comcast.net

LOS ANGELES, CA

Summertime in Los Angeles County features a diverse array of accordion related activities as part of the popular program the J.A.M. Sessions. This program allows participants of all skill level to explore an art form as a community. Move to the beat or explore a new instrument as you connect with diverse artists and cultures at the J.A.M. (Jazzed and Motivated) Sessions. These free and interactive events take place throughout the summer and are centered around movement, music and drumming. All ages and levels of experience are welcome and all events are free.

Accordion Night! on June 25, 7 PM is titled 'Long live the accordion!' where attendees are invited to join in a fun night with accordion superstars Otoño Luján (of Conjunto Los Pochos) and Gee Rabe (of Lisa Haley & the Zydekats). Participants have the opportunity to try out button and piano accordions and be part of a giant accordion symphony! Accordions are provided courtesy of Hohner, Inc. and this event is recommended for ages 12 and up.

Big! World! Fun! Family Series: A Gaelic Gathering: Irish Music and Dance will be held on Saturday July 7 at 10 AM. This event features A Gaelic Gathering: Irish Music and Dance. Stirring melodies, intricate footwork and the rhythmic step and Ceili (group) dances make Gaelic Gathering a feast of exuberant Irish tunes and dances. Instrumentalists including Alice Ryan, who sings haunting songs and plays accordion accompany the dancers and perform. Together they guide the audience on an exploration of Ireland's rich cultural heritage.

J.A.M. Sessions at Mayberry Park: Accordion Night, July 10 at 6 PM

J.A.M. Sessions at the Ford: Klezmer Music, July 16 at 7 PM

J.A.M. Sessions at East L.A. Civic Center: Accordion Night, July 27 at 6 PM

J.A.M. Sessions at Recreation Park: Accordion Night, August 4 at 6 PM

Big! World! Fun! Family Series: The Dustbowl Revival, August 25 at 10 AM

Concierto Fiesta Mexicana X: September 29 at 7 PM

For more information, please visit: <http://fordtheatres.org> or contact Steve Lozier, J.A.M. Sessions Marketing Coordinator, phone: 323-610-5912 or by e-mail: SLozier@arts.lacounty.gov

PRINCETON, NJ

Dr. Robert Young McManhan, AAA Board of Director will perform with the New Jersey Symphony Orchestra, Mark Laycock, conductor, and boys chorus, July 26, 8:00 PM, Richardson Auditorium, Princeton, NJ, in a performance of Arrigo Boito's Prologue to Mephistofele.]



LINDENHURST, NY

Accordionist Bud Gramer performs every Tuesday evening from 5:30 PM – 8:30 PM at the Village Lanterne Restaurant, located at 143 N. Wellwood Ave., in Lindenhurst, (LI) New York. For more information and directions, please phone (631) 225-1690.



SUPERIOR, WI

The Alex Meixner Band will in concert at the Harrington ARTS Center and A World of Accordions Museum, 1401 Belknap St., Superior, WI 54880 on July 5, 2012 6:00 PM (Doors open at 5:00 PM).

Alex Meixner has reached star status among multi-generational audi-



ences as a Grammy Award nominee and national entertainer on diatonic and piano accordions, brasses, and vocals. His repertory covers the gamut between ethnic and pop music. Members of the band include Tom Jones on saxes, clarinet, flute, guitar and vocals, and Michael Morris on drums and vocals. Paul Vargason (of Superior) will perform the opening act. Tickets: Advance purchase: \$20.00, www.brownpapertickets.com: \$23.00 and at the door: \$25.00. To reserve tickets or for more information phone (715) 395-2787.

MILWAUKEE, WI

On Monday - July 23, 2012, Betty Jo Simon will perform as the featured artist at the Milwaukee Accordion Club (MAC). Betty Jo brings endless enthusiasm to the stage. A vivacious performer who enjoys intimate concert settings where she can talk with her audience, Betty Jo has a wide repertoire from which to choose. Her favorite? "Around the World with the MIDI Accordion." Betty Jo performs as a soloist throughout the United States and internationally. In 2000 she appeared on a Chinese satellite TV musical variety program aired on Chinese New Year and went on to give concerts in Beijing and Shanghai. In 2007 she won the AAA Maddalena Belfiore Entertainment Competition for Female Accordionist and currently leads a German polka band called The Alpen Spielers. In August 2009 she performed as soloist with the Auckland Symphony Orchestra at three different venues, one being the opening concert of the 64th Annual CIA Coupe Mondiale World Accordion Championships. For more information, please visit www.accordions.com/mac ■

Submitting Your News Item for Publication in the September Issue

You are invited to submit your news as soon as possible for the September edition of the AAA Newsletter. Our AAA members are involved in a diverse array of activities, and I thank you in advance for taking the time to prepare the press information and pictures so that we can share your work and events with our readership.

All material for consideration for the September newsletter can be sent to me at goaccordion@yahoo.com or to aaa1938@aol.com. Please include "AAA Newsletter" in the subject

box, so that we don't miss any items that come in. Text should be sent within the e-mail or as a Word .doc attachment. Pictures should be sent as a high quality .jpg file, and the larger the file size the better. We can always reduce/crop the picture if necessary, however we are unable to increase the quality from smaller pictures. The deadline for the September newsletter will be the August 15.zz

Thanks again for your help and support, and I wish you all a wonderful summer.

Kevin Friedrich, Editor – AAA Newsletter

Join the
Celebration!!!



75th Anniversary
1938-2013

The New Yorker Hotel

481 Eighth Avenue at 34th Street

New York, NY 10001

August 14-18, 2013

www.ameraccord.com